

FireCR flash

Service Manual



FireCR Flash Computed Radiography Reader

Doc No.: TM-411-EN

Rev: 1.2.1 Nov 2014

Part No.: CR-FPM-51-005-EN

3DISC, **FireCR**, **FireCR Flash** and **Quantor** are trademarks of **3D Imaging & Simulations Corp**, South Korea, and its affiliates. All other trademarks are held by their respective owners and are used in an editorial fashion with no intention of infringement.

The data in this publication are for illustration purposes only and do not necessarily represent standards or specifications, which must be met by **3D Imaging & Simulations Corp**.

All information contained herein is intended for guidance purposes only, and characteristics of the products and services described in this publication can be changed at any time without notice. Products and services may not be available in your local area. Please contact your local sales representative for availability information.

3D Imaging & Simulations Corp strives to provide as accurate information as possible, but shall not be responsible for any typographical error.

© Copyright 2014 **3D Imaging & Simulations Corp**, all rights reserved, printed, and published in South Korea by **3D Imaging & Simulations Corp**.

Table of contents

Parts removal/replacement

Replacing the top cover	1
Replacing the fiber optics module	3
Replacing the laser steering module.....	6
Replacing the stage Assembly	9
Replacing the cassette lock motors	13
Replacing the housing assembly.....	15
Calibration	16
Spare part list.....	18

When ordering parts, please inform the technical supporter the serial number of the unit being repaired.

The serial number can be found on the back of the scanner.

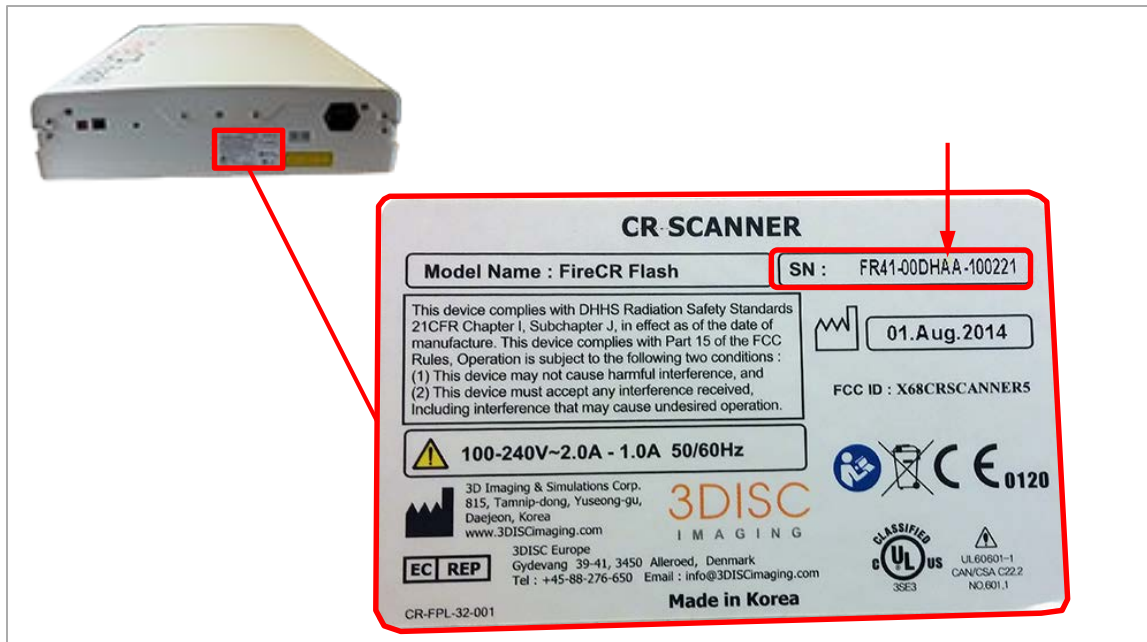

Parts removal/replacement

Replacing the top cover

1. Switch the reader off on the back and unplug both cables.



2. Remove the 4 screws using a 3 mm hex key.

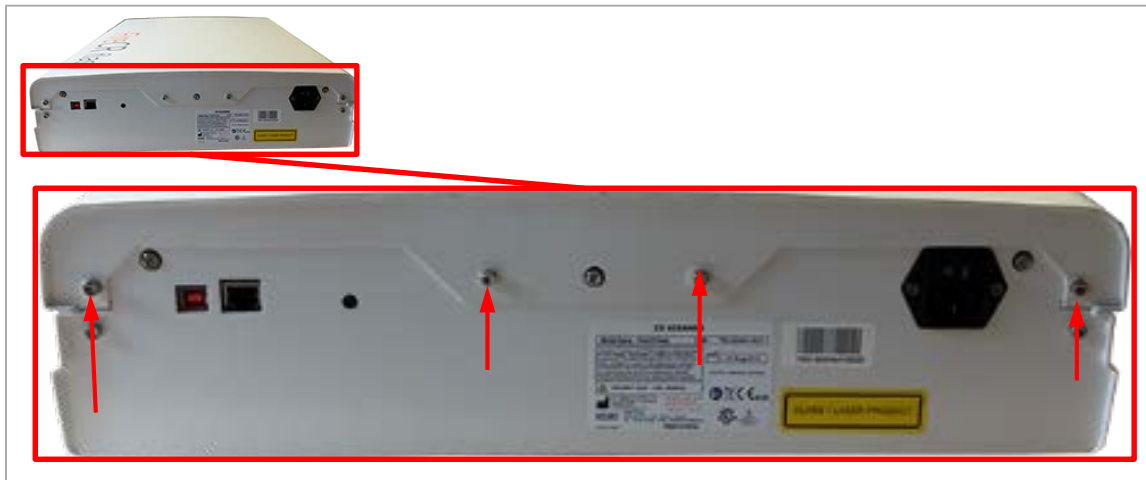

3. Move the top cover towards the back and lift it off. The cover has a tight fit, and a bit of force has to be applied to move it.



- When mounting the new top cover, or remounting the old top cover, ensure that locks on the top cover is seated in the guides in the bottom cover, then move it towards the front to lock it in place.



- Insert and fasten the 4 screws in the back of the scanner using a 3 mm hex key.

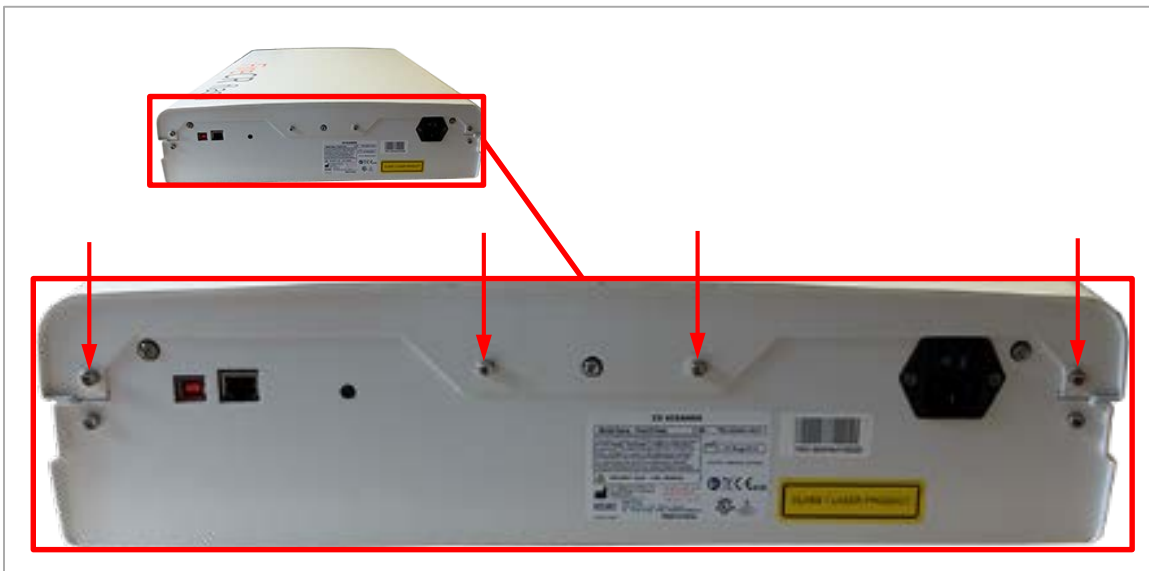

Replacing the fiber optics module

1. Follow step 1 through 3 of [Replacing the top cover](#).
2. Remove the 3 screws on the back using a 3 mm hex key.



3. Tilt the cover off the laser steering assembly.

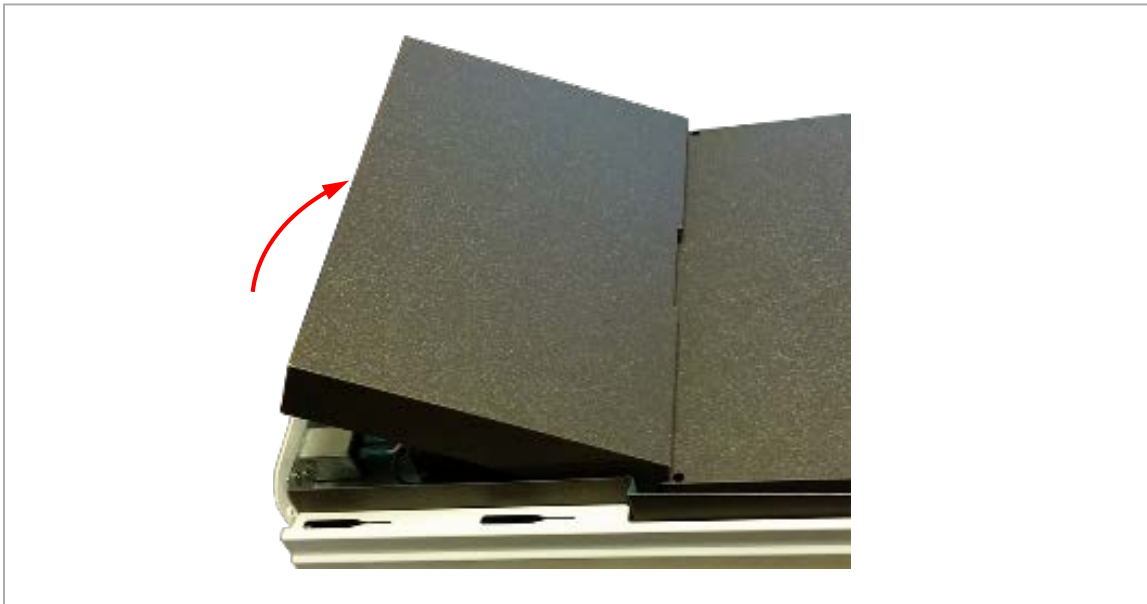

4. Unplug the connectors shown from the laser steering module. Bear in mind that screw (1) must be removed using a 2.5 mm hex key before the multicable (2) can be unplugged.

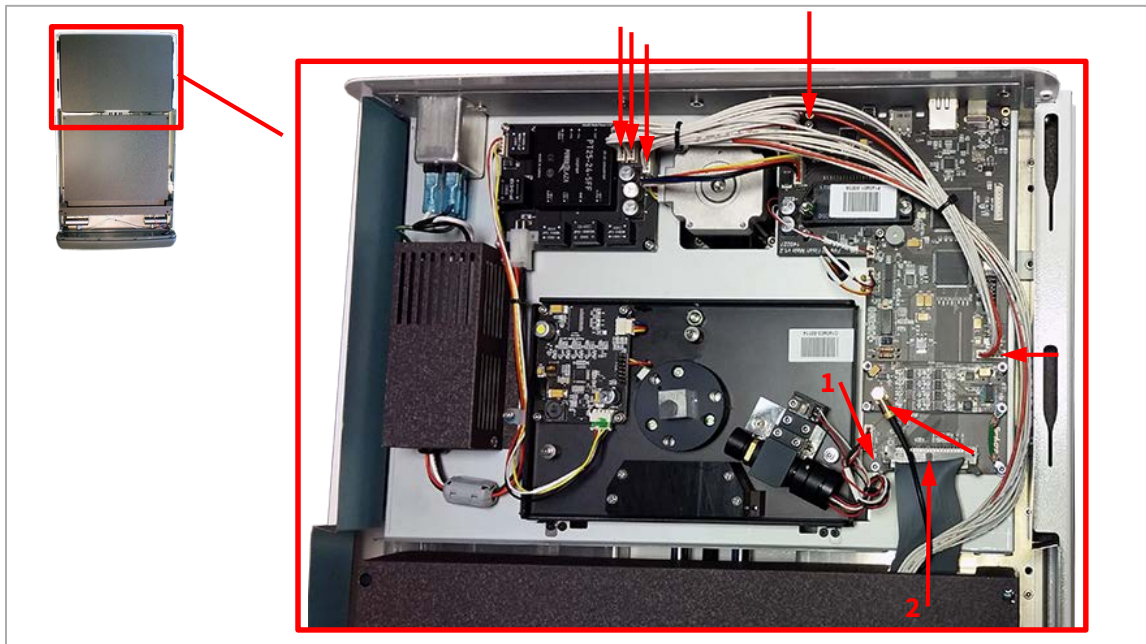

5. Remove the 8 screws using a 3 mm hex key. It is recommended to use a magnetic tool for the two rear screws.

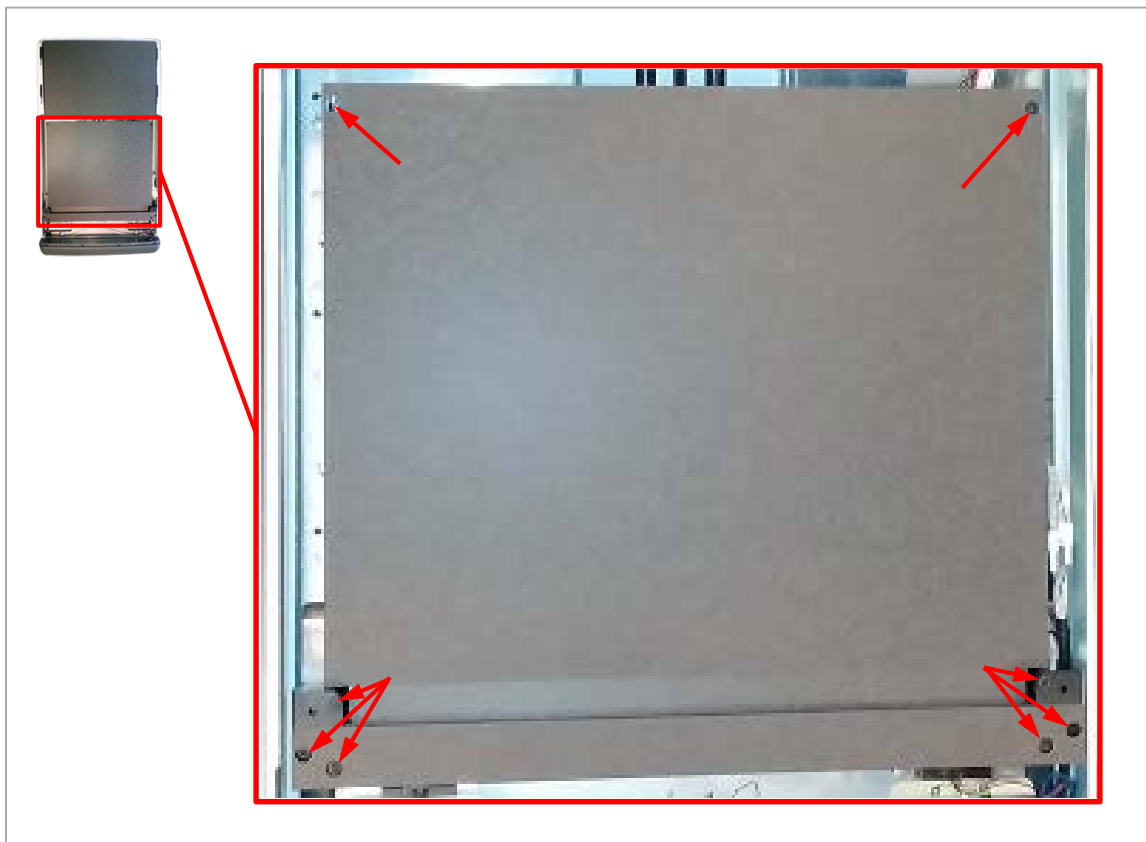

6. Unplug the two connectors beside the fiber optics module.

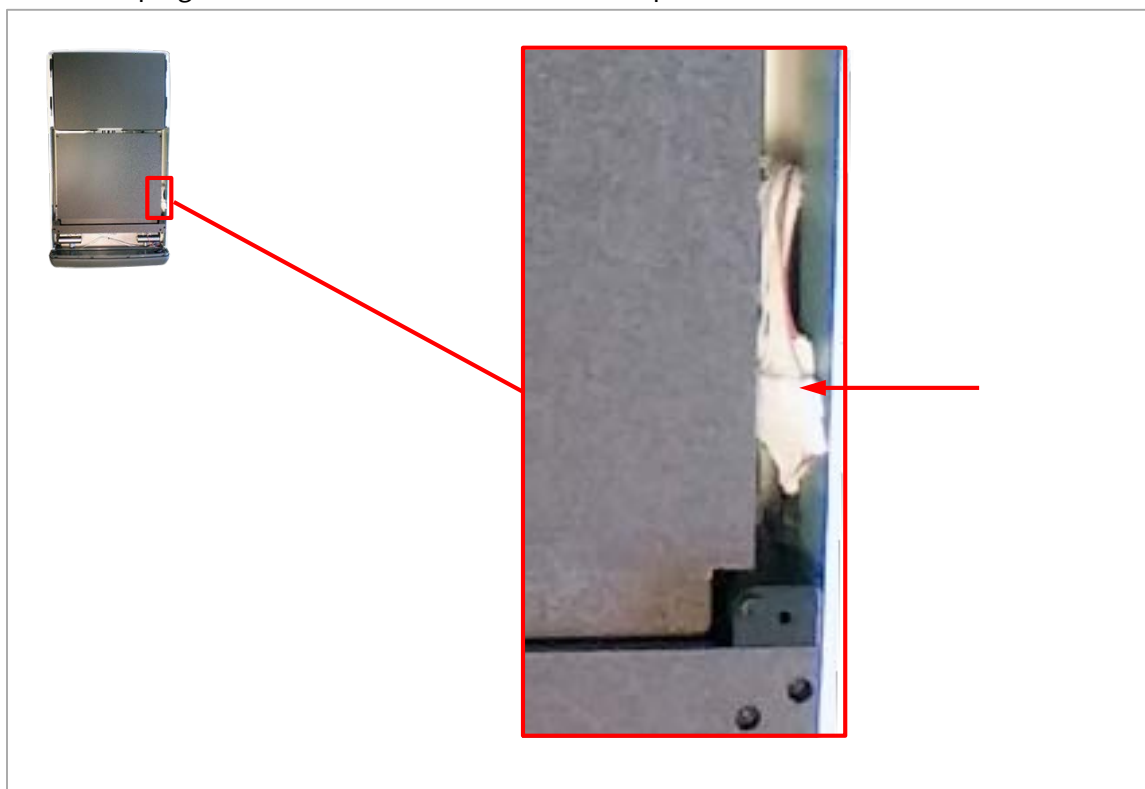

7. Carefully lift the fiber optics module out of the scanner.

8. Install in reverse order and calibrate the unit as described under calibration.

Replacing the laser steering module

1. Follow step 1 through 3 of [Replacing the top cover](#).
2. Follow step 2 through 7 of [Replacing the fiber optics module](#).
3. Unplug the limit sensor and Y-axis motor from the main board PCB.



4. Remove the 4 screws holding the Y-axis motor using a 3 mm hex key.

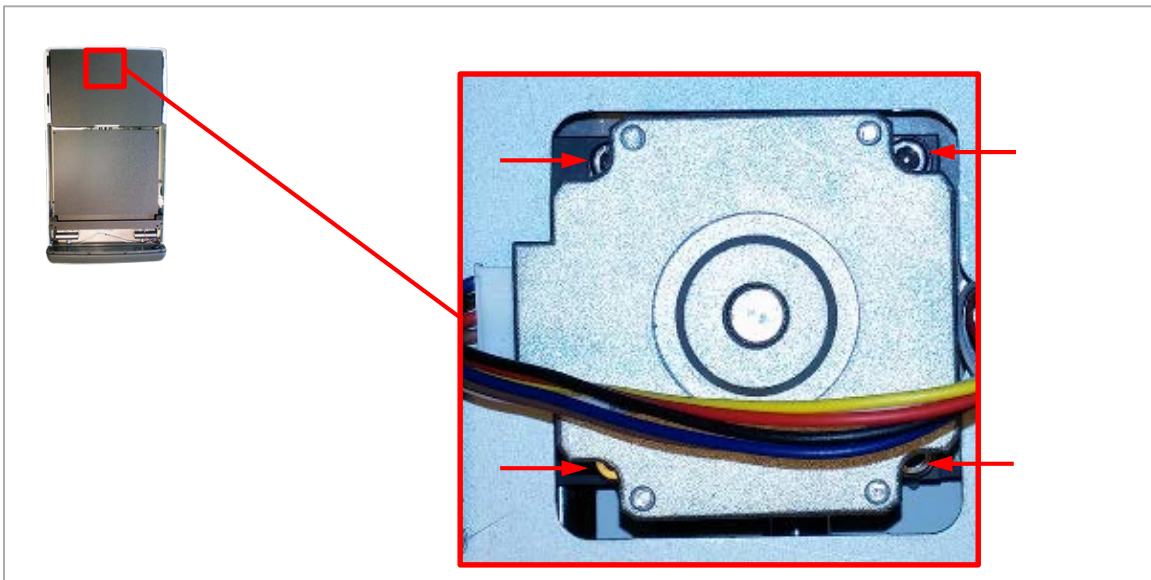

5. Carefully lift the Y-axis motor out of the scanner.

6. Unplug the three wires from the mains switch.

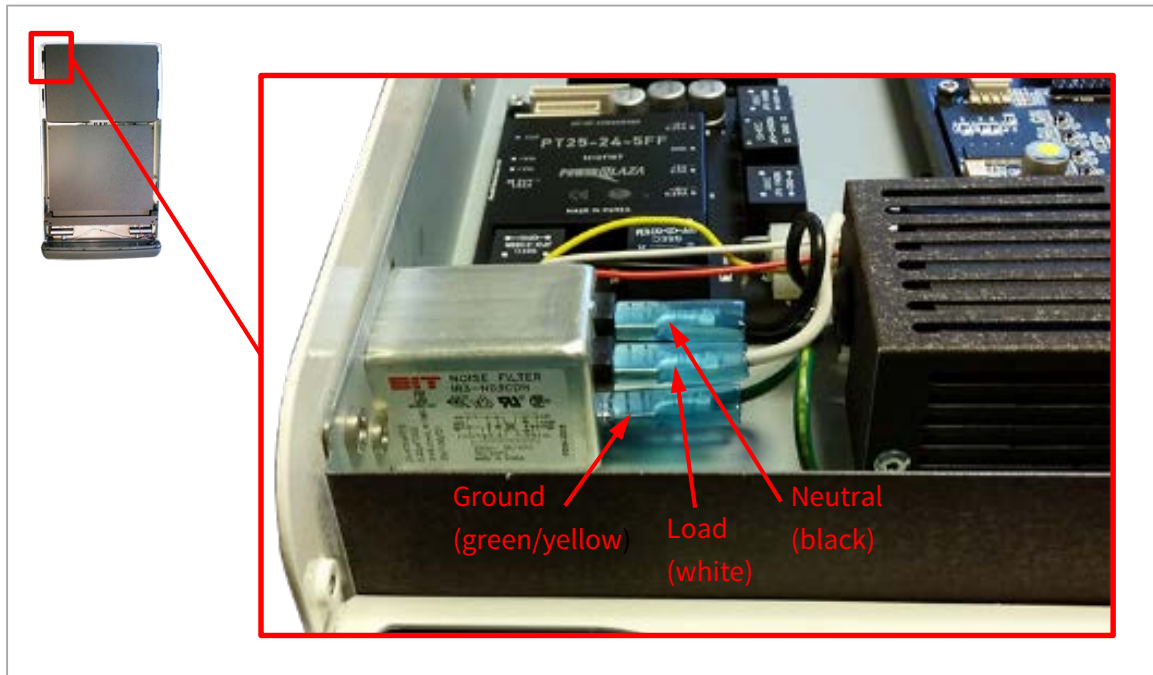

7. Remove the 2 screws holding the mains power switch using a PH #1 screwdriver.



8. Remove the mains power switch out of the back of the chassis.



9. Remove the 4 screws holding the laser steering assembly using a 3 mm hex key.

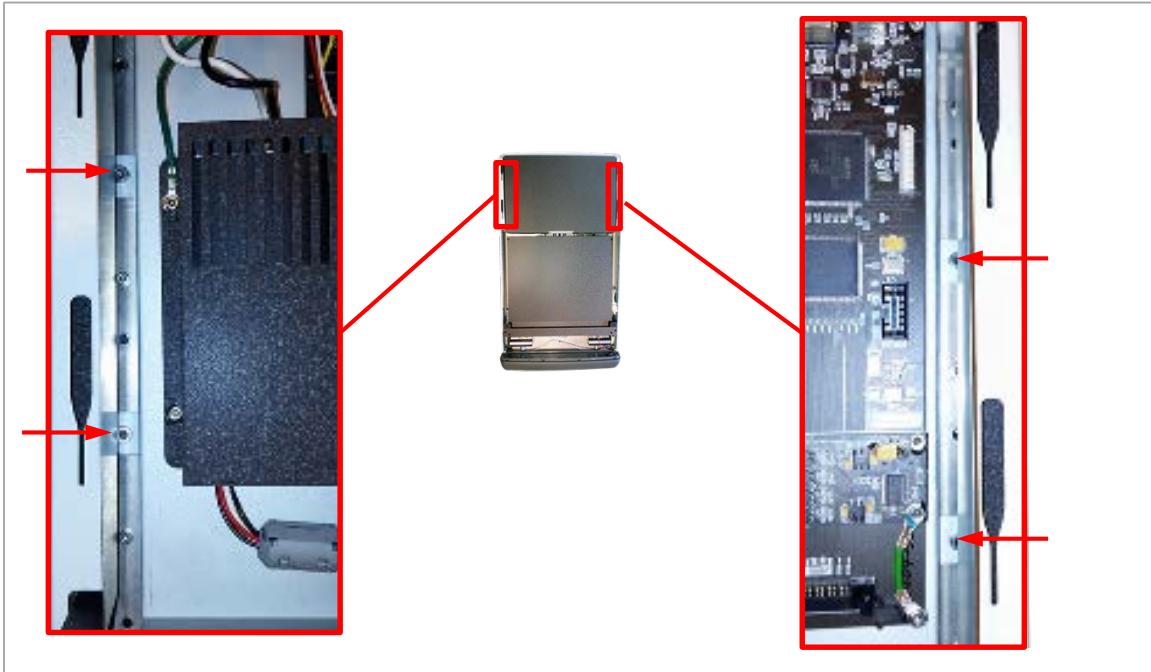

10. Slide the module towards the front and lift it out of the chassis.

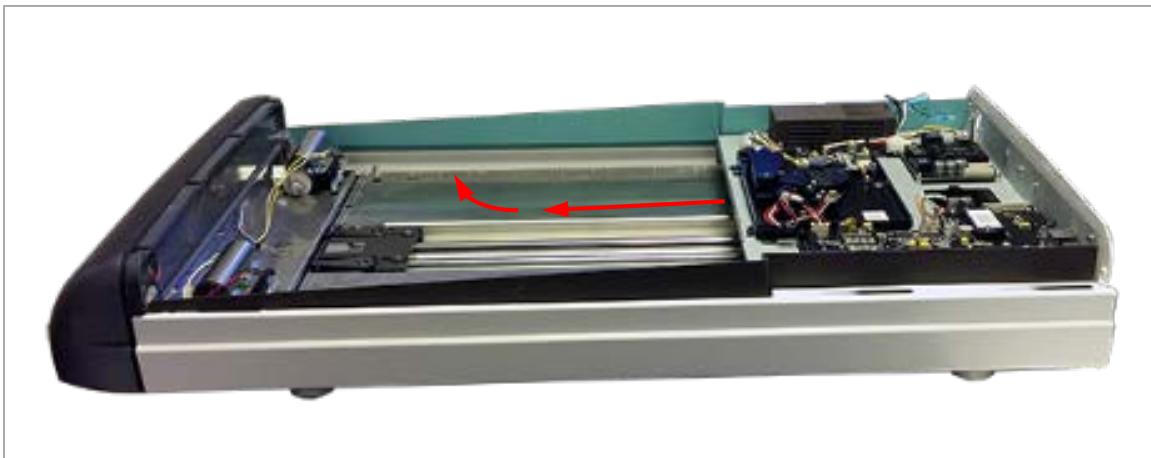

11. Install in reverse order and calibrate the unit as described under calibration.

Replacing the stage Assembly

1. Follow step 1 through 3 of [Replacing the top cover](#).
2. Follow step 2 through 7 of [Replacing the fiber optics module](#).
3. Follow step 3 through 10 of [Replacing the Laser steering module](#).
4. Turn the scanner over to gain access to the bottom and remove the 4 screws holding the mouth piece using a PH1 screwdriver.
5. Carefully tilt the mouth piece, do **NOT** pull it off as this could damage or breaking the wires for the LED indicator.

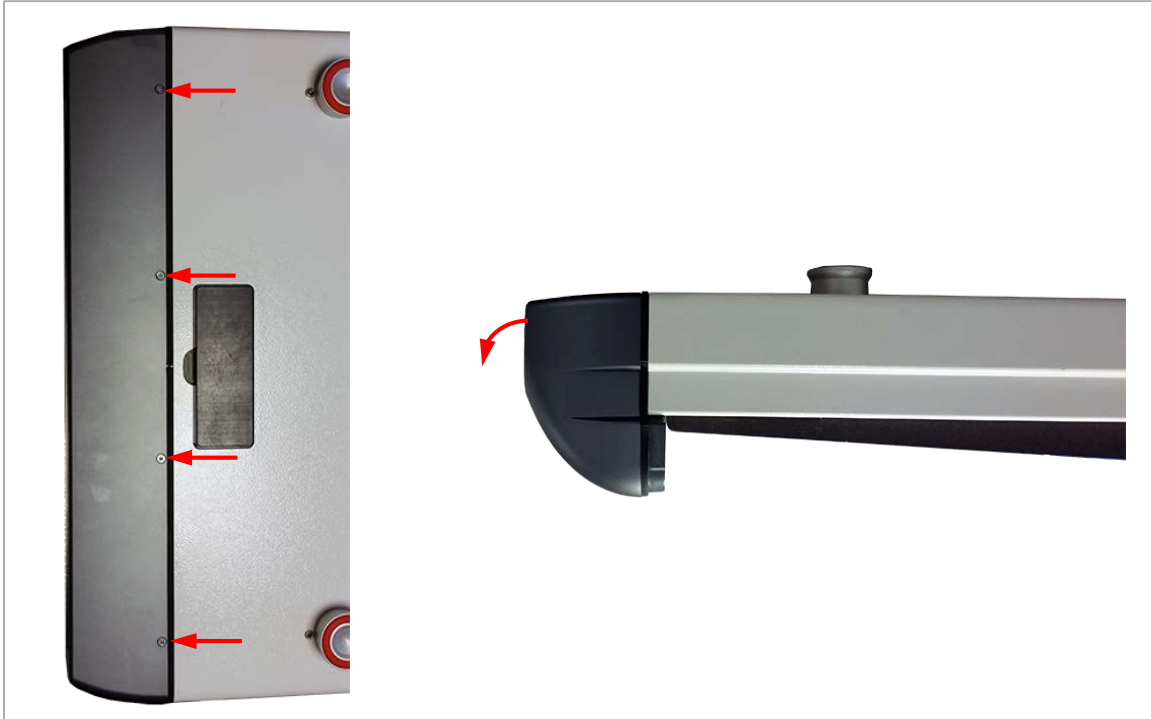

6. Unplug the connector for the LED and remove the mouth piece.



7. Turn the scanner over and remove the 3 screws (1) using a 4 mm hex key, then remove the last 2 screws (2) using a 3 mm hex key. Lift off the metal frame.



8. Remove the 4 screws using a 4 mm hex key. Pull the plastic frame off the bottom cover.



9. Turn the scanner over to gain access to the bottom and remove the 4 feet by rotating them counterclockwise.

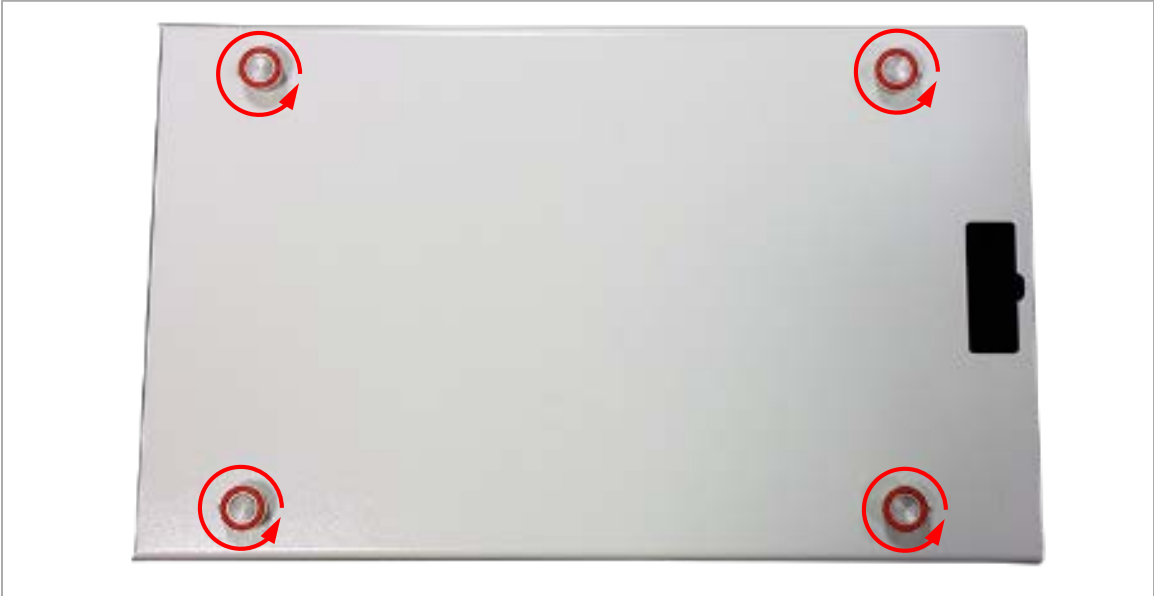

10. Remove the 4 screws using a 2.5 mm hex key.



11. Turn the scanner over and carefully slide the stage assembly towards the front and out of the bottom cover.

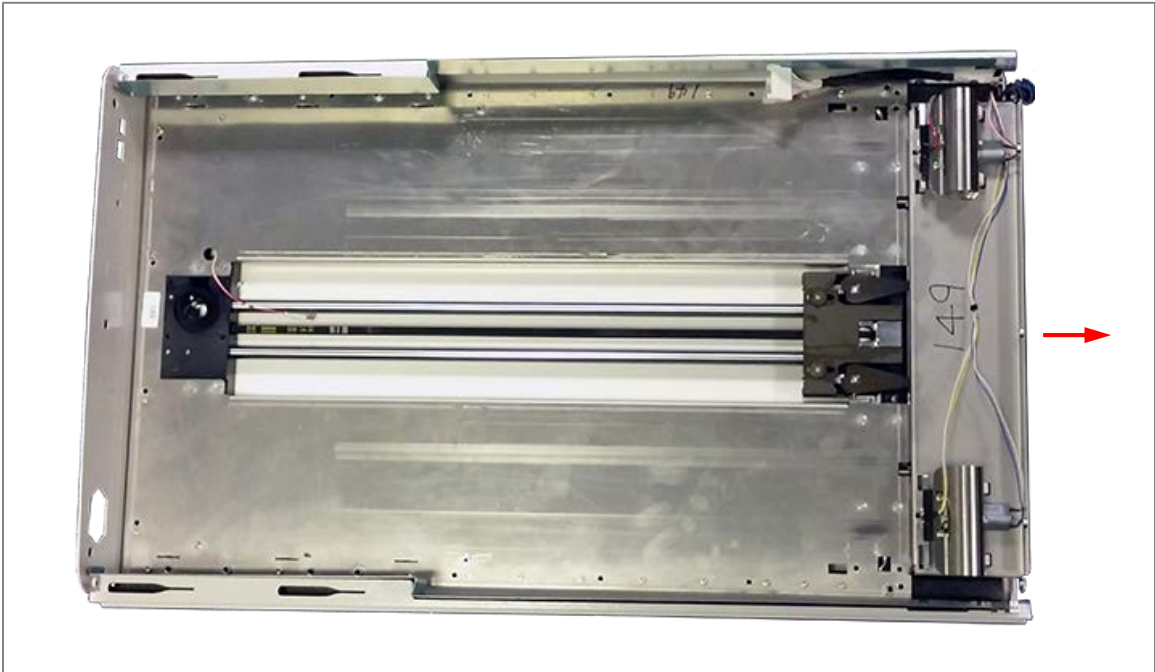

12. Install in reverse order.

Replacing the cassette lock motors

1. Follow step 1 through 3 of [Replacing the top cover](#).
2. Follow step 2 through 7 of [Replacing the fiber optics module](#).
3. Follow step 3 through 10 of [Replacing the laser steering module](#).
4. Follow step 4 through 9 of [Replacing the stage assembly](#).
5. Turn the stage over and unplug the connector for the cassette lock motor to be replaced.

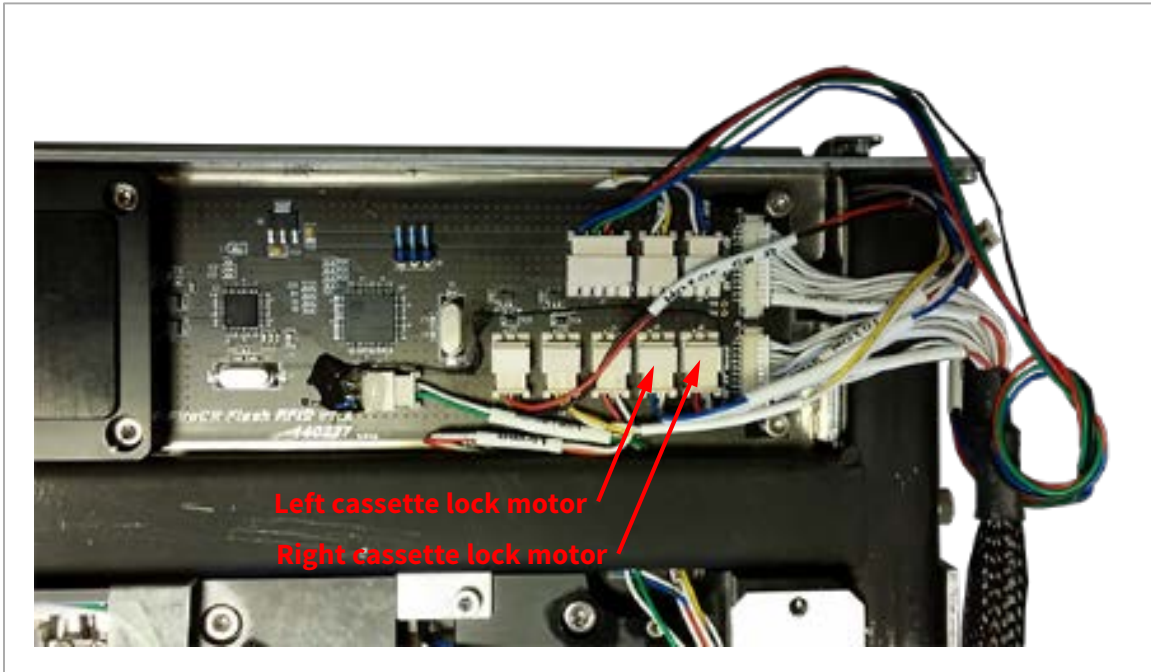

6. Turn the stage assembly over again and remove the two screws holding the defective cassette lock motor in place using a 2.5 mm hex key.

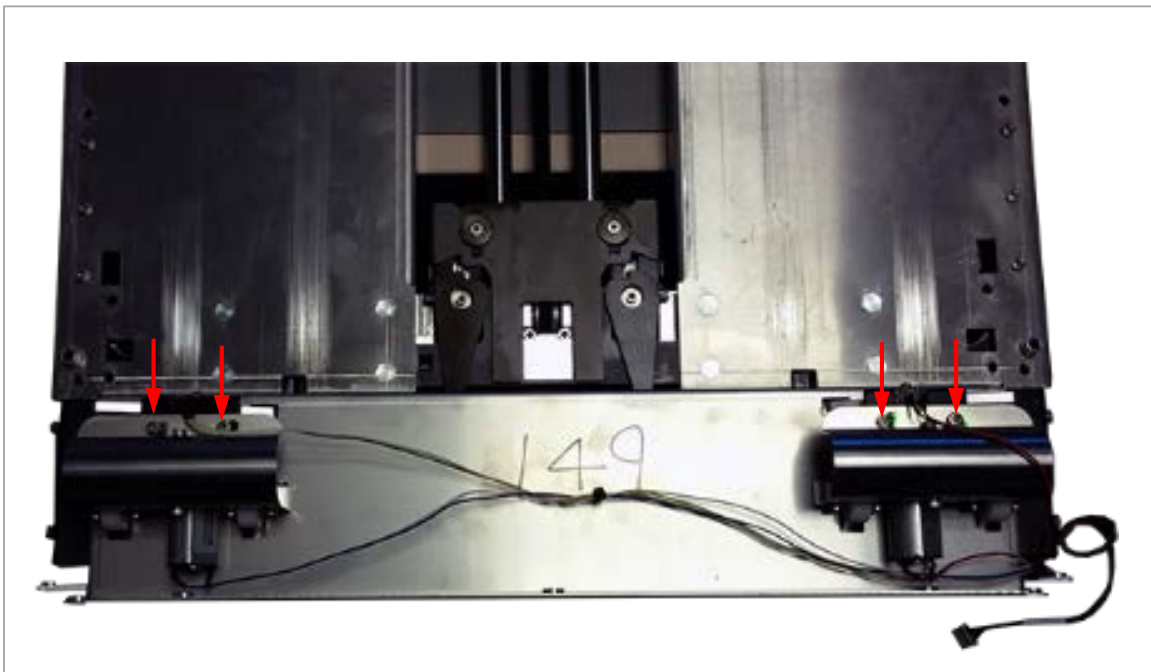

7. Remove the screw holding the locking arm using a 1.5 mm hex key. Then remove the locking arm.

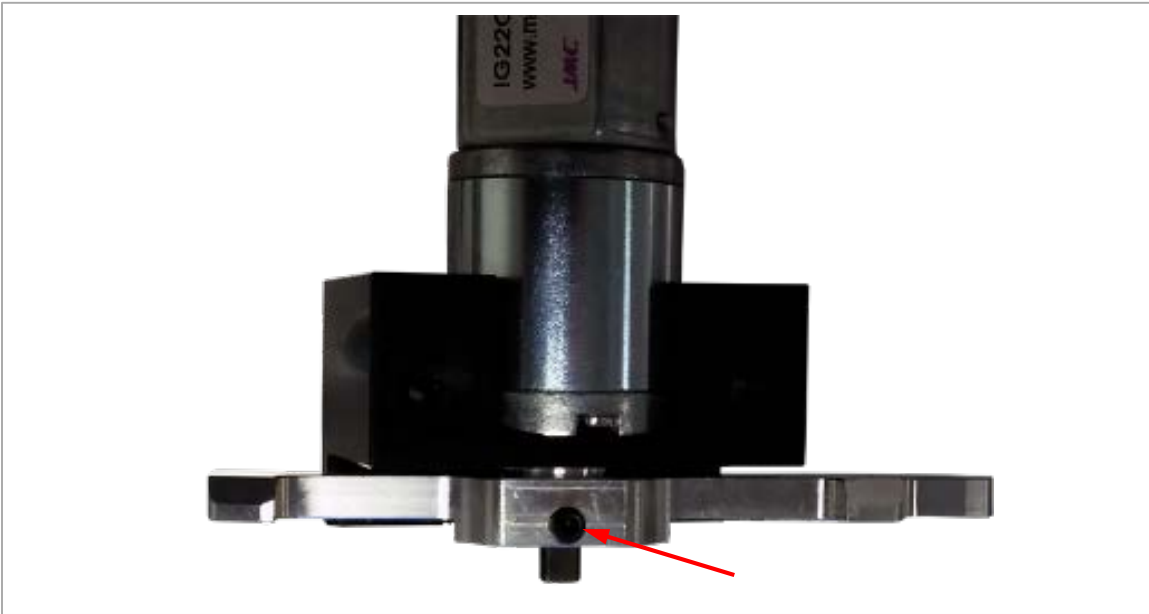

8. Remove the 4 screws holding the motor to the bracket using a PH1 Screwdriver.

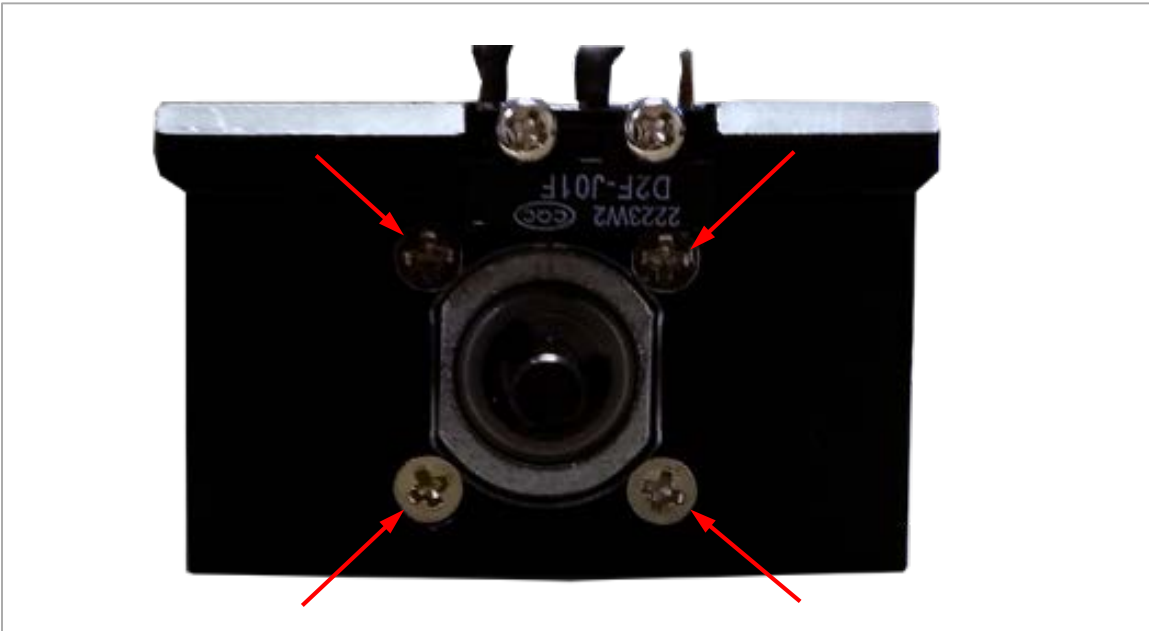

9. Install in reverse order.

Replacing the housing assembly.

1. Follow step 1 through 3 of Replacing the top cover.
2. Follow step 2 and 3 of Replacing the fiber optics module.
3. Follow step 6, through 8 of Replacing the laser steering module.
4. Follow step 4 through 11 of Replacing the stage assembly.
5. Replace the housing assembly.
6. Install in reverse order.

Calibration

Each Flash scanner has two calibration sets installed, and these should be updated if either the laser steering module or the fiber optics module are replaced. To update the calibration, please set the scanner up in a tabletop installation and follow the steps below, the same steps should be followed with the scanner wall mounted afterwards to ensure all calibration files are updated properly.

1. Connect the scanner to the PC and power outlet, switch it on.



1. Open Quantor and select the system menu in the top right hand corner of the screen.

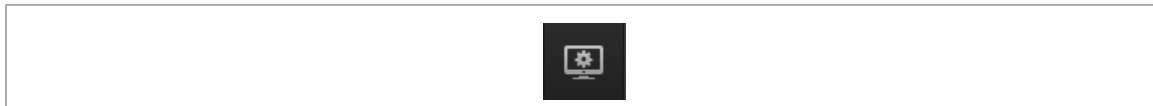

2. Select "Device calibration".

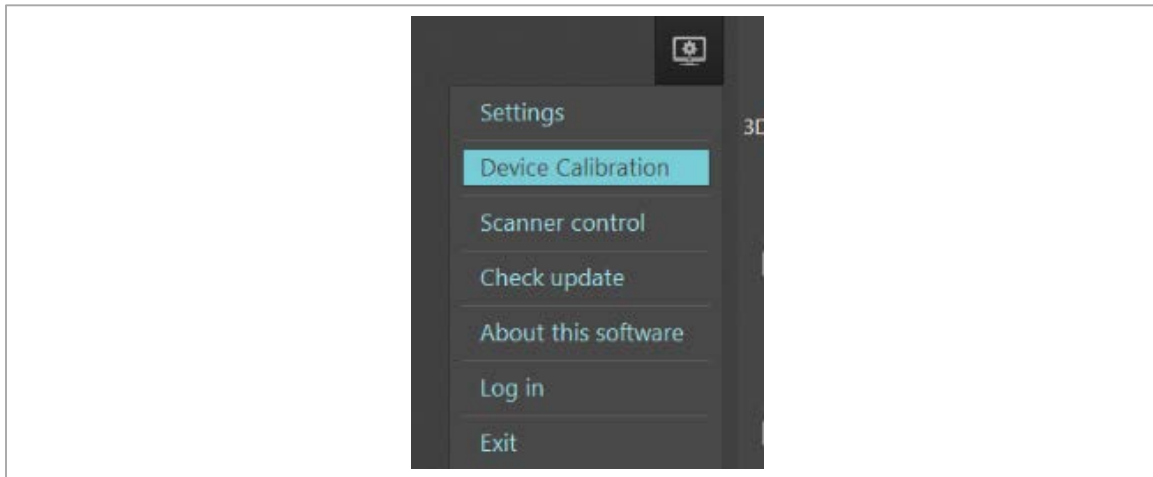

3. Go through each step starting with erasing the large cassette, then the blank calibration scan, followed by low dose, mid dose and finally high dose calibrations scans. The generator settings under each calibration step is merely a guide, the settings may vary for each generator when calibrating, the important part is to get scans that results in green numbers.

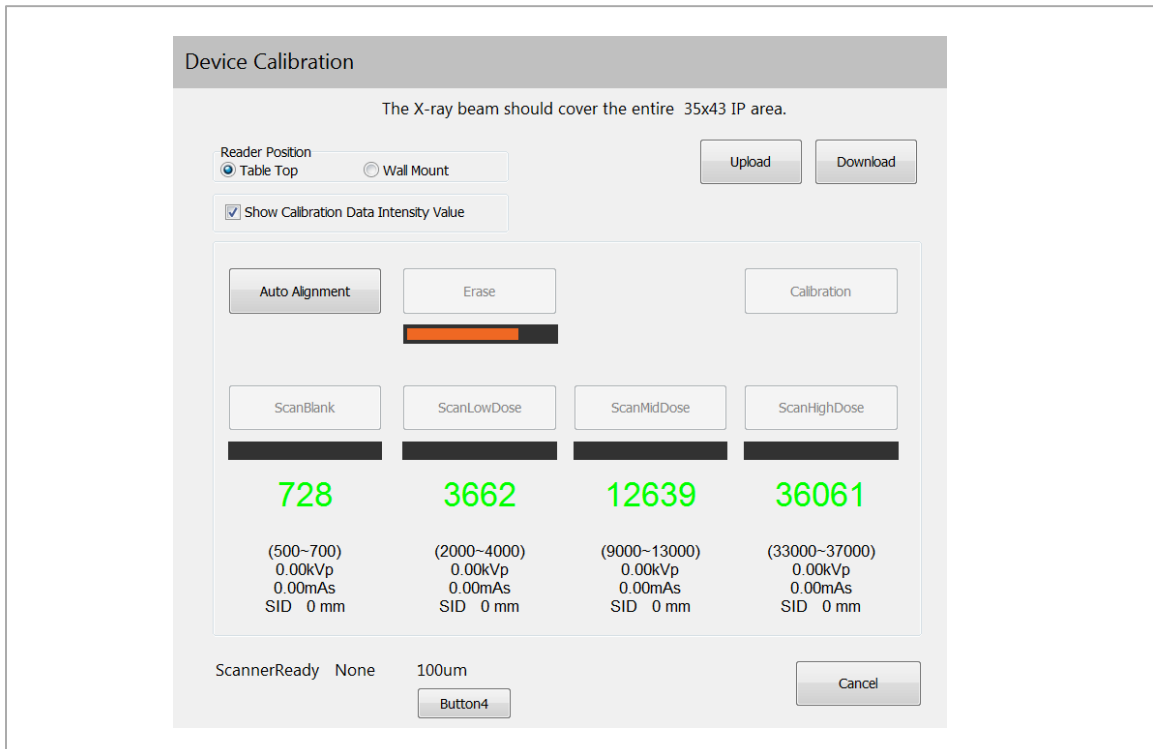

4. Once the calibration is complete, select Calibration and allow the scanner to upload the calibration data. The upload will take approximately 10 minutes.

Spare part list

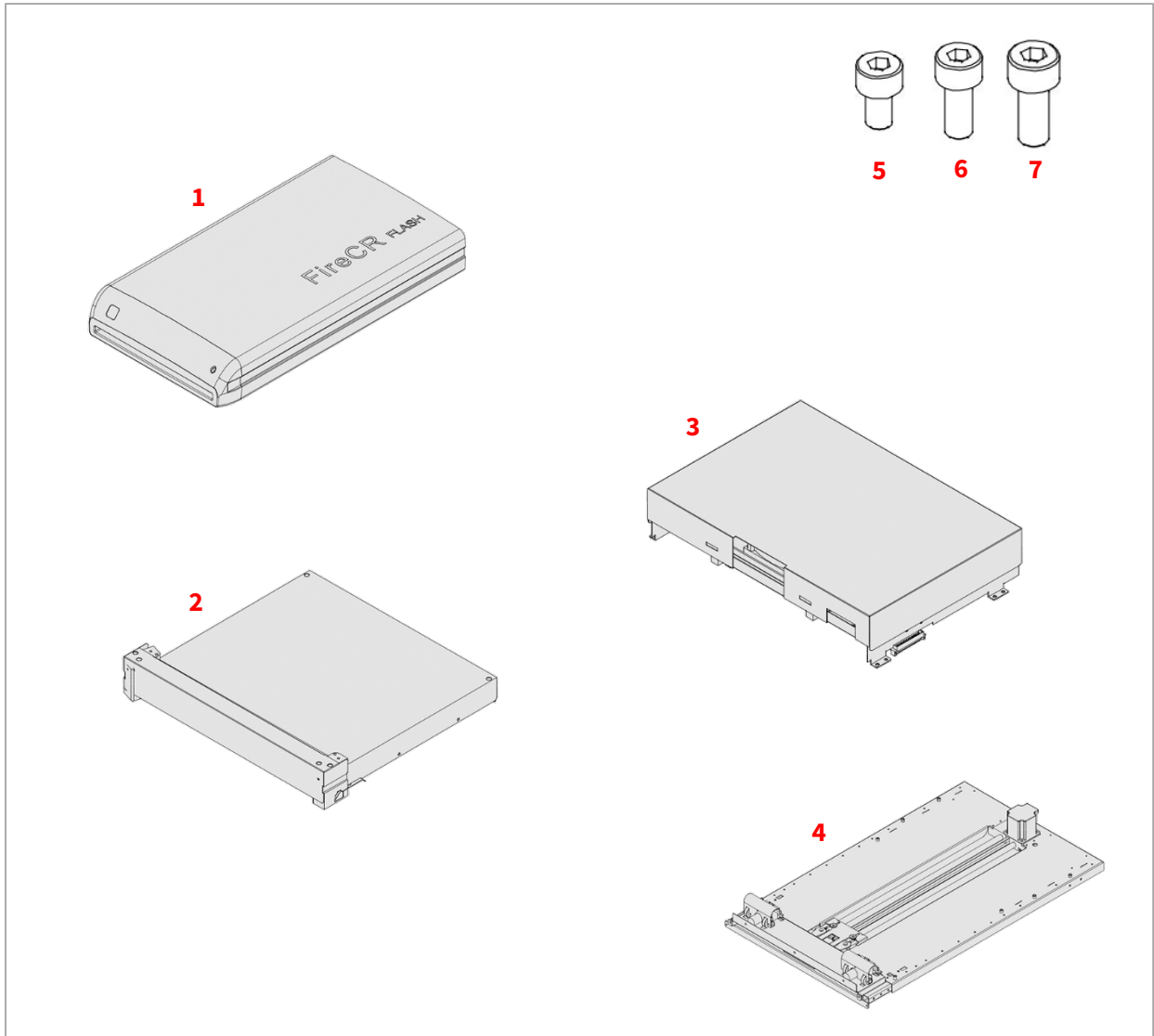

Position	Description	Part number
1	Housing assembly	CR-CM-AE-001
2	Fiber optics module	CR-CM-AE-004
3	Laser steering module	CR-CM-AE-006
4	Stage assembly	CR-CM-AE-002
5	Screw, hex 3x5 mm (bag of 20 pcs)	SCR-20PK-35
6	Screw, hex 3x8 mm (bag of 20 pcs)	SCR-20PK-38
7	Screw, hex 4x8 mm (bag of 20pcs)	SCR-20PK-48

- These parts have to be pre-programmed for the individual unit from the factory.

3DISC

I M A G I N G

3D Imaging & Simulations Corp. (3DISC)

Bldg. 1, 48, Yuseong-daero 1184 beon-gil,
Yuseong-Gu,
Daejeon, Korea
Tel: +82 42 931 2100
Fax: +82 42 931 2299
E-mail: info@3DISCimaging.com

3DISC Americas, Inc.

22560 Glenn Drive, Suite 116
Sterling, VA 20164
United States
Tel: +1 800 570 0363

EC REP

3DISC Europe ApS

Gydevang 39-41
3450 Alleroed
Denmark
Tel: +45 88 276 650